

TAA SERIES UNITS

Lennox TAA model blower-coil units are designed for up flow or horizontal air and indoor applications only. TAA blower units are available in six models; 072, 090, 120, 150, 180 and 240. The units match up with Lennox TSA condensing units and Lennox TPA heat pump units charged with HFC-410A refrigerant.

Information and specifications contained in this manual are subject to change. Procedures outlined in this manual are presented as a recommendation only and do not supersede or replace local or state codes.

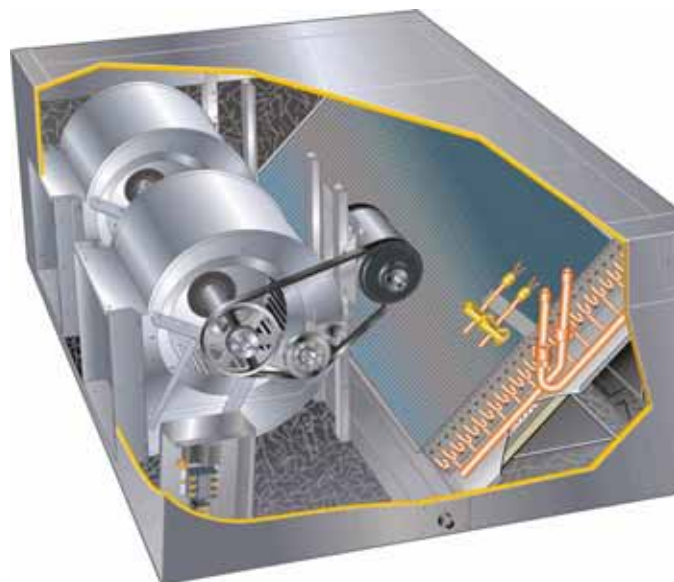

⚠ WARNING

Improper installation, adjustment, alteration, service or maintenance can cause personal injury, loss of life, or damage to property.

Installation and service must be performed by a licensed professional installer (or equivalent) or a service agency.

⚠ WARNING



Electric shock hazard. Can cause injury or death. Before attempting to perform any service or maintenance, turn the electrical power to unit OFF at disconnect switch(es). Unit may have multiple power supplies.

TABLE of CONTENTS

Specifications Page 2
Options / Accessories Page 4
Blower Data Page 5
Electric Heat Data Page 15
I Unit Components Page 21
II Refrigeration System Page 22
III Blower Speed and Belt Adjustment .. Page 22
IV Electric Heat Page 23
V Diagrams Page 24

SPECIFICATIONS

General Data	Model No.	TAA072S4S	TAA090S4D
	Nominal Tonnage	6	7.5
Connections	Liquid line o.d. - in. (sweat)	(1) 5/8	(2) 5/8
	Suction/Vapor line o.d. - in. (sweat)	(1) 1-1/8	(2) 7/8
	Condensate drain - in. (fpt)	1 (NPT)	1 (NPT)
Refrigerant	Not Furnished	R-410A	R-410A
Evaporator Coil	Net face area - sq. ft.	8.2	8.2
	Coil (Face) Split - 1st stage / 2nd stage (%)	- - -	50 / 50
	Tube diameter - in.	3/8	3/8
	Number of rows	3	4
	Fins per inch	17	17
Blower and Drive		See Blower Drive Specifications Table on Page 12	
	Wheel nominal diameter & width - in.	(1) 15 x 15	(1) 15 x 15
Filter	Number and size - in.	(3) 16 x 25 x 2	(3) 16 x 25 x 2

SPECIFICATIONS

General Data	Model No.	TAA120S4D	TAA150S4D	TAA180S4D	TAA240S4D
	Nominal Tonnage	10	12.5	15	20
Connections	Liquid line o.d. - in. (sweat)	(2) 5/8	(2) 5/8	(2) 5/8	(2) 5/8
	Suction/Vapor line o.d. - in. (sweat)	(2) 7/8	(2) 7/8	(2) 1-1/8	(2) 1-1/8
	Condensate drain - in. (fpt)	1 (NPT)	1 (NPT)	1 (NPT)	1 (NPT)
Refrigerant	Not Furnished	R-410A	R-410A	R-410A	R-410A
Evaporator Coil	Net face area - sq. ft.	11.3	11.3	16.9	16.9
	Coil (Face) Split - 1st stage / 2nd stage (%)	50 / 50	50 / 50	50 / 50	50 / 50
	Tube diameter - in.	3/8	3/8	3/8	3/8
	Number of rows	4	4	3	4
	Fins per inch	14	14	14	14
Blower and Drive		See Blower Drive Specifications Table on Page 12			
	Wheel nominal diameter & width - in.	(1) 15 x 15	(1) 15 x 15	(2) 15 x 15	(2) 15 x 15
Filter	Number and size - in.	(4) 16 x 25 x 2	(4) 16 x 25 x 2	(6) 16 x 25 x 2	(6) 16 x 25 x 2

OPTIONS / ACCESSORIES

Item	Catalog No.	072	090	120	150	180	240
BLOWER							
Blower Drives							
		See Blower Drive Specifications Table on Page 12					
CABINET							
Corrosion Protection	Factory	○	○	○	○	○	○
Float Switch	T2SNSR71LN1- 91W69	x	x	x	x	x	x
Return Air Grille	T2GARD30L-1 47W49	x	x				
	T2GARD30M-1 47W50			x	x		
	T2GARD30N-1 47W51					x	x
CONTROLS							
L Connection® Network	See separate bulletin	x	x	x	x	x	x
MSAV KIT							
MOTOR SIZE	VOLTAGE/ PHASE						
2HP	208/240V-3PH	T2MSAV20LM1Y 92W63		x	x		
	460V-3PH	T2MSAV20LM1G 92W64		x	x		
	575V-3PH	T2MSAV20LM1J 92W65		x	x		
3HP	208/240V-3PH	T2MSAV20LN1Y 92W66		x	x	x	x
	460V-3PH	T2MSAV20LN1G 92W67		x	x	x	x
	575V-3PH	T2MSAV20LN1J 92W68		x	x	x	x
5HP	208/240V-3PH	T2MSAV20MN1Y 92W69				x	x
	460V-3PH	T2MSAV20MN1G 92W70				x	x
	575V-3PH	T2MSAV20MN1J 92W71				x	x
7.5HP	208/240V-3PH	T2MSAV20N-1Y 92W72					x
	460V-3PH	T2MSAV20N-1G 92W73					x
	575V-3PH	T2MSAV20N-1J 92W74					x

NOTE - The catalog and model numbers that appear here are for ordering field installed accessories only.

○ - Factory Installed with extended lead time.

x - Field Installed.

OPTIONS / ACCESSORIES (continued)

Item		Catalog No.	072	090	120	150	180	240
ELECTRIC HEAT								
10 kW	208/240V-3ph - T3EH0010LM1Y	46W50	x	x	x	x		
	460V-3ph - T3EH0010LM1G	46W55	x	x	x	x		
	575V-3ph - T3EH0010LM1J	46W60	x	x	x	x		
15 kW	208/240V- 3ph - T3EH0015LM1Y	46W51	x	x	x	x		
	460V-3ph - T3EH0015LM1G	46W56	x	x	x	x		
	575V-3ph - T3EH0015LM1J	46W61	x	x	x	x		
25 kW	208/240V-3ph - T3EH0025LM1Y	46W52	x	x	x	x		
	460V-3ph - T3EH0025LM1G	46W57	x	x	x	x		
	575V-3ph - T3EH0025LM1J	46W62	x	x	x	x		
35 kW	208/240V-3ph - T3EH0035LM1Y	46W53		x	x	x		
	460V-3ph - T3EH0035LM1G	46W58		x	x	x		
	575V-3ph - T3EH0035LM1J	46W63		x	x	x		
20 kW	208/240V-3ph - T3EH0020N-1Y	46W65					x	x
	460V-3ph - T3EH0020N-1G	46W69					x	x
	575V-3ph - T3EH0020N-1J	46W73					x	x
30 kW	208/240V-3ph - T3EH0030N-1Y	46W66					x	x
	460V-3ph - T3EH0030N-1G	46W70					x	x
	575V-3ph - T3EH0030N-1J	46W74					x	x
40 kW	208/240V-3ph - T3EH0040N-1Y	49W39					x	x
	460V-3ph - T3EH0040N-1G	49W40					x	x
	575V-3ph - T3EH0040N-1J	49W41					x	x
50 kW	208/240V-3ph - T3EH0050N-1Y	46W67					x	x
	460V-3ph - T3EH0050N-1G	46W71					x	x
	575V-3ph - T3EH0050N-1J	46W75					x	x
ECONOMIZER								
	T2ECON31L-1-	44W94	x	x				
	T2ECON31M-1-	44W95			x	x		
	T2ECON31N-1-	44W96					x	x
Economizer Controls								
	Differential Enthalpy Control	17W71	x	x	x	x	x	x
INDOOR AIR QUALITY								
Air Filters								
¹ Healthy Climate® High Efficiency Air Filters (16 x 25 x 5)	MERV 10 - HCF16-10	X6670	x	x	x	x	x	x
	MERV 16 - HCF16-16	X6672	x	x	x	x	x	x
5 Inch Filter Mounting Kits	T2FLTR70L-1-	47W71	x	x				
	T2FLTR70M-1-	47W72			x	x		
	T2FLTR70N-1-	47W73					x	x
Healthy Climate® UVC Light Kit (208/230V-1ph)	208/230V - T2UVCL10LM1	46W43	x	x	x	x		
	208/230V - T2UVCL10N-1	46W44					x	x
	² 460V/230V Step-Down Transformer	96M07	x	x	x	x	x	x
	² 575V/230V Step-Down Transformer	96M08	x	x	x	x	x	x
REFRIGERANT SYSTEM								
Freezestat	T2SNSR70N1-	91W70	x	x	x	x	x	x
Heat Pump Check Valve Kit	T2CVLV10N-1-	47W48					x	
	T2CVLV11N-1-	50W73						x

NOTE - The catalog and model numbers that appear here are for ordering field installed accessories only.

X - Field Installed.

¹ Order 5 in. Filter Mounting Kit and required number of MERV 10 or MERV 16 filters: - (3) 072-090, (4) 120-150, (6) 180-240.

² Step-down transformer (460V or 575V to 208/230V-1ph) or separate power supply is required.

BLOWER DATA

TAA072 BLOWER PERFORMANCE

All data is measured external to the unit with dry coil and standard 2 in. air filters in place.

FOR ALL UNITS ADD:

1 - Wet indoor coil air resistance of selected unit.

2 - Any field installed accessories air resistance (electric heat, economizer, etc.) See page 13.

Then determine from table the blower motor hp and drive rpm required. See page 12 for blower drive specifications.

Air Volume cfm	STATIC PRESSURE EXTERNAL TO UNIT - Inches Water Gauge															
	0.1		0.2		0.3		0.4		0.5		0.6		0.7		0.8	
	RPM	BHP	RPM	BHP	RPM	BHP	RPM	BHP	RPM	BHP	RPM	BHP	RPM	BHP	RPM	BHP
1900	428	0.57	479	0.66	531	0.74	581	0.81	629	0.88	675	0.94	718	1.01	758	1.07
2000	434	0.59	486	0.69	538	0.77	589	0.84	637	0.91	682	0.98	725	1.05	765	1.11
2100	441	0.62	493	0.72	545	0.8	596	0.88	644	0.95	689	1.02	732	1.09	771	1.15
2200	448	0.65	501	0.75	553	0.83	604	0.91	652	0.98	696	1.06	738	1.13	778	1.2
2300	456	0.68	508	0.78	561	0.86	612	0.94	659	1.02	704	1.1	746	1.17	785	1.24
2400	463	0.71	516	0.81	569	0.9	620	0.98	667	1.06	711	1.14	753	1.22	792	1.29
2500	470	0.74	524	0.84	578	0.94	629	1.02	675	1.1	719	1.19	760	1.27	798	1.34
2600	478	0.77	533	0.88	587	0.98	637	1.06	683	1.15	726	1.24	767	1.32	805	1.39
2700	486	0.81	542	0.92	596	1.02	646	1.11	692	1.2	734	1.29	775	1.37	812	1.45
2800	495	0.85	552	0.96	606	1.07	655	1.16	700	1.25	742	1.34	782	1.42	819	1.5
2900	504	0.89	561	1.01	616	1.11	665	1.2	708	1.3	750	1.39	789	1.48	826	1.56
3000	514	0.93	572	1.05	626	1.16	674	1.26	717	1.35	758	1.45	797	1.54	833	1.62

Air Volume cfm	STATIC PRESSURE EXTERNAL TO UNIT - Inches Water Gauge													
	0.9		1		1.1		1.2		1.3		1.4		1.5	
	RPM	BHP	RPM	BHP	RPM	BHP	RPM	BHP	RPM	BHP	RPM	BHP	RPM	BHP
1900	796	1.13	830	1.19	862	1.25	893	1.32	922	1.39	950	1.46	978	1.54
2000	802	1.17	836	1.23	868	1.3	898	1.37	928	1.44	956	1.52	983	1.6
2100	808	1.22	842	1.28	874	1.35	904	1.42	933	1.5	961	1.58	988	1.66
2200	814	1.26	848	1.33	879	1.4	909	1.48	938	1.56	966	1.64	993	1.73
2300	820	1.31	854	1.38	885	1.46	915	1.53	943	1.62	971	1.7	998	1.79
2400	827	1.36	860	1.43	891	1.51	920	1.59	949	1.68	976	1.77	1003	1.86
2500	833	1.41	866	1.49	897	1.57	926	1.66	954	1.75	981	1.84	1008	1.93
2600	840	1.47	872	1.55	902	1.63	932	1.72	960	1.81	987	1.91	1013	2.01
2700	846	1.53	878	1.61	908	1.7	937	1.79	965	1.88	992	1.98	1018	2.08
2800	853	1.58	884	1.67	914	1.76	943	1.86	970	1.96	997	2.06	1023	2.16
2900	859	1.65	890	1.74	920	1.83	948	1.93	975	2.03	1002	2.14	1028	2.24
3000	866	1.71	896	1.8	926	1.9	954	2	981	2.11	1007	2.22	1032	2.33

TAA090 BLOWER PERFORMANCE

All data is measured external to the unit with dry coil and standard 2 in. air filters in place.

FOR ALL UNITS ADD:

1 - Wet indoor coil air resistance of selected unit.

2 - Any field installed accessories air resistance (electric heat, economizer, etc.) See page 13.

Then determine from table the blower motor hp and drive rpm required. See page 12 for blower drive specifications.

Air Volume cfm	STATIC PRESSURE EXTERNAL TO UNIT - Inches Water Gauge															
	0.1		0.2		0.3		0.4		0.5		0.6		0.7		0.8	
	RP M	BHP	RP M	BHP	RP M	BHP	RP M	BHP	RP M	BHP	RP M	BHP	RP M	BHP	RP M	BHP
1600	430	0.52	485	0.62	539	0.71	590	0.77	636	0.83	680	0.88	721	0.94	758	0.99
1700	439	0.55	494	0.65	548	0.74	599	0.80	645	0.86	688	0.91	729	0.97	766	1.03
1800	448	0.58	503	0.68	558	0.77	608	0.83	654	0.89	697	0.95	737	1.01	774	1.08
1900	457	0.62	513	0.72	567	0.80	617	0.86	663	0.93	705	0.99	745	1.06	781	1.12
2000	467	0.65	523	0.75	577	0.83	627	0.90	672	0.96	714	1.03	753	1.10	789	1.17
2100	477	0.68	533	0.78	587	0.86	637	0.93	681	1.00	723	1.08	762	1.15	797	1.22
2200	487	0.72	543	0.82	597	0.90	646	0.97	691	1.05	732	1.12	770	1.20	805	1.27
2300	497	0.75	554	0.85	608	0.94	657	1.01	700	1.09	741	1.17	779	1.25	813	1.32
2400	508	0.79	565	0.89	619	0.98	667	1.06	710	1.14	750	1.23	787	1.30	822	1.38
2500	519	0.83	577	0.94	630	1.02	677	1.10	720	1.19	759	1.28	796	1.36	830	1.43
2600	531	0.87	588	0.98	641	1.07	688	1.16	729	1.25	769	1.34	805	1.42	839	1.49
2700	543	0.92	600	1.03	653	1.12	698	1.21	739	1.31	778	1.40	814	1.48	848	1.55
2800	555	0.97	613	1.08	664	1.17	709	1.27	749	1.37	788	1.46	824	1.54	857	1.62
2900	568	1.02	625	1.13	676	1.22	719	1.32	759	1.43	797	1.52	833	1.60	866	1.68
3000	581	1.07	638	1.18	687	1.28	730	1.39	769	1.49	807	1.58	842	1.67	875	1.75
3100	595	1.12	651	1.24	699	1.34	740	1.45	779	1.56	817	1.65	852	1.73	883	1.82
3200	609	1.18	664	1.30	710	1.41	751	1.52	789	1.63	827	1.72	861	1.80	892	1.89
3300	624	1.24	677	1.36	722	1.48	761	1.59	799	1.70	836	1.79	870	1.88	901	1.97
3400	639	1.30	690	1.43	733	1.55	772	1.67	810	1.77	846	1.86	879	1.95	909	2.05
3500	653	1.37	703	1.50	745	1.62	782	1.75	820	1.85	856	1.94	888	2.03	917	2.14
3600	668	1.44	715	1.57	756	1.70	793	1.83	830	1.93	865	2.02	897	2.12	925	2.24

Air Volume cfm	STATIC PRESSURE EXTERNAL TO UNIT - Inches Water Gauge													
	0.9		1.0		1.1		1.2		1.3		1.4		1.5	
	RPM	BHP	RPM	BHP	RPM	BHP	RPM	BHP	RPM	BHP	RPM	BHP	RPM	BHP
1600	793	1.05	826	1.1	859	1.15	891	1.21	923	1.27	952	1.34	981	1.42
1700	800	1.09	833	1.15	866	1.20	899	1.26	930	1.33	959	1.40	987	1.48
1800	807	1.13	840	1.19	873	1.25	906	1.31	936	1.38	966	1.46	994	1.54
1900	815	1.18	848	1.24	881	1.30	913	1.36	943	1.44	972	1.52	1000	1.60
2000	823	1.23	856	1.29	889	1.35	921	1.42	951	1.50	979	1.58	1007	1.67
2100	830	1.28	863	1.34	896	1.40	928	1.48	958	1.56	986	1.65	1013	1.74
2200	838	1.33	871	1.39	904	1.46	935	1.54	965	1.63	993	1.72	1020	1.81
2300	846	1.39	880	1.45	912	1.52	943	1.61	972	1.70	999	1.79	1026	1.88
2400	855	1.44	888	1.51	920	1.59	950	1.67	979	1.77	1006	1.86	1033	1.96
2500	863	1.50	896	1.57	928	1.65	958	1.74	986	1.84	1013	1.94	1039	2.04
2600	872	1.56	904	1.64	936	1.72	965	1.82	993	1.92	1019	2.02	1045	2.12
2700	880	1.62	913	1.70	943	1.79	972	1.89	1000	2.00	1026	2.10	1052	2.20
2800	889	1.69	921	1.77	951	1.87	979	1.97	1006	2.08	1033	2.18	1058	2.29
2900	898	1.76	929	1.85	959	1.95	987	2.05	1013	2.16	1039	2.26	1064	2.37
3000	906	1.83	937	1.93	966	2.03	994	2.13	1020	2.24	1046	2.35	1070	2.46
3100	914	1.91	944	2.01	973	2.11	1001	2.22	1027	2.33	1052	2.44	1077	2.55
3200	922	1.99	952	2.09	980	2.20	1008	2.30	1033	2.41	1058	2.53	1083	2.64
3300	930	2.07	959	2.18	987	2.29	1014	2.39	1040	2.50	1065	2.62	1089	2.73
3400	938	2.16	966	2.27	994	2.38	1021	2.49	1046	2.60	1071	2.71	1095	2.83
3500	945	2.26	973	2.37	1001	2.48	1028	2.58	1053	2.69	1077	2.81	1101	2.93
3600	953	2.35	980	2.47	1008	2.58	1034	2.68	1059	2.79	1084	2.91	1107	3.03

TAA120 BLOWER PERFORMANCE

All data is measured external to the unit with dry coil and standard 2 in. air filters in place.

FOR ALL UNITS ADD:

1 - Wet indoor coil air resistance of selected unit.

2 - Any field installed accessories air resistance (electric heat, economizer, etc.) See page 13.

Then determine from table the blower motor hp and drive rpm required. See page 12 for blower drive specifications.

Air Volume cfm	STATIC PRESSURE EXTERNAL TO UNIT - Inches Water Gauge															
	0.1		0.2		0.3		0.4		0.5		0.6		0.7		0.8	
	RP M	BHP	RP M	BHP	RP M	BHP	RP M	BHP	RP M	BHP	RP M	BHP	RP M	BHP	RP M	BHP
2200	428	0.09	463	0.2	501	0.32	541	0.45	585	0.60	632	0.75	674	0.84	712	0.88
2400	441	0.19	476	0.29	513	0.41	553	0.54	596	0.68	642	0.82	681	0.9	715	0.94
2600	455	0.29	489	0.39	525	0.50	565	0.63	608	0.77	654	0.90	687	0.96	720	1.01
2800	469	0.40	502	0.49	538	0.60	577	0.72	621	0.85	667	0.99	693	1.03	727	1.09
3000	484	0.51	516	0.60	552	0.70	591	0.82	635	0.95	677	1.07	699	1.10	736	1.18
3200	499	0.62	531	0.70	566	0.80	606	0.92	651	1.06	684	1.15	707	1.18	746	1.28
3400	514	0.73	546	0.81	582	0.91	622	1.03	667	1.17	690	1.22	717	1.28	758	1.40
3600	529	0.84	562	0.93	598	1.03	639	1.15	679	1.28	697	1.31	730	1.40	772	1.52
3800	545	0.96	579	1.05	616	1.15	658	1.28	686	1.37	706	1.41	745	1.53	786	1.65
4000	562	1.09	596	1.18	634	1.29	674	1.41	693	1.46	720	1.54	761	1.67	802	1.79
4200	580	1.23	615	1.31	654	1.42	684	1.52	702	1.57	737	1.69	778	1.82	819	1.94
4400	600	1.37	635	1.45	672	1.56	691	1.62	717	1.72	756	1.86	796	1.98	836	2.09
4600	619	1.51	655	1.59	683	1.68	702	1.76	736	1.89	775	2.02	814	2.13	853	2.24
4800	639	1.65	673	1.73	692	1.81	719	1.93	757	2.08	795	2.19	832	2.30	871	2.40
5000	659	1.78	685	1.87	706	1.97	740	2.12	778	2.26	814	2.37	851	2.46	889	2.56

Air Volume cfm	STATIC PRESSURE EXTERNAL TO UNIT - Inches Water Gauge													
	0.9		1.0		1.1		1.2		1.3		1.4		1.5	
	RPM	BHP	RPM	BHP	RPM	BHP	RPM	BHP	RPM	BHP	RPM	BHP	RPM	BHP
2200	751	0.96	795	1.08	839	1.21	884	1.34	928	1.48	971	1.61	1014	1.73
2400	755	1.03	801	1.16	847	1.29	892	1.43	936	1.56	981	1.70	1024	1.83
2600	762	1.11	808	1.24	855	1.38	901	1.52	946	1.65	990	1.79	1034	1.92
2800	770	1.20	816	1.33	863	1.47	910	1.61	955	1.75	1000	1.88	1044	2.01
3000	779	1.29	826	1.42	873	1.56	919	1.70	964	1.84	1009	1.98	1054	2.11
3200	790	1.40	836	1.53	882	1.66	929	1.80	974	1.94	1019	2.07	1063	2.21
3400	802	1.51	847	1.64	893	1.77	938	1.91	983	2.04	1028	2.17	1072	2.31
3600	815	1.64	859	1.76	904	1.89	949	2.03	993	2.16	1037	2.29	1080	2.42
3800	829	1.77	873	1.90	917	2.03	961	2.16	1005	2.29	1048	2.42	1090	2.55
4000	845	1.91	888	2.04	932	2.17	975	2.31	1018	2.43	1060	2.56	1102	2.69
4200	861	2.06	904	2.19	948	2.32	990	2.46	1033	2.59	1074	2.71	1116	2.84
4400	878	2.21	921	2.34	963	2.47	1006	2.60	1048	2.73	1089	2.86	1130	2.98
4600	894	2.36	936	2.49	979	2.61	1021	2.74	1063	2.87	1104	3.00	1145	3.12
4800	911	2.51	953	2.63	995	2.76	1036	2.88	1078	3.01	1119	3.13	1161	3.26
5000	928	2.67	969	2.78	1011	2.90	1052	3.03	1094	3.15	1135	3.27	1176	3.40

TAA150 BLOWER PERFORMANCE

All data is measured external to the unit with dry coil and standard 2 in. air filters in place.

FOR ALL UNITS ADD:

1 - Wet indoor coil air resistance of selected unit.

2 - Any field installed accessories air resistance (electric heat, economizer, etc.) See page 13.

Then determine from table the blower motor hp and drive rpm required. See page 12 for blower drive specifications.

Air Volume cfm	STATIC PRESSURE EXTERNAL TO UNIT - Inches Water Gauge															
	0.1		0.2		0.3		0.4		0.5		0.6		0.7		0.8	
	RP M	BHP	RP M	BHP	RP M	BHP	RP M	BHP	RP M	BHP	RP M	BHP	RP M	BHP	RP M	BHP
2800	500	0.49	537	0.59	578	0.72	622	0.86	668	0.99	694	1.03	729	1.10	771	1.20
3000	519	0.60	556	0.71	597	0.83	642	0.97	681	1.08	704	1.11	743	1.20	785	1.30
3200	538	0.71	576	0.82	618	0.95	663	1.10	690	1.15	717	1.21	758	1.31	800	1.42
3400	558	0.83	597	0.95	640	1.09	680	1.21	698	1.24	734	1.33	776	1.44	818	1.55
3600	579	0.97	620	1.09	664	1.23	689	1.30	712	1.35	753	1.47	795	1.58	837	1.69
3800	602	1.11	644	1.24	681	1.35	698	1.39	731	1.49	773	1.61	815	1.72	857	1.84
4000	627	1.26	669	1.39	690	1.45	714	1.52	754	1.65	795	1.76	835	1.87	877	1.98
4200	653	1.42	684	1.52	701	1.57	736	1.69	777	1.82	816	1.92	856	2.02	897	2.13
4400	676	1.57	694	1.63	721	1.73	761	1.87	800	1.99	838	2.08	877	2.18	917	2.28
4600	688	1.70	710	1.79	747	1.93	787	2.06	823	2.16	860	2.24	898	2.33	938	2.43
4800	702	1.85	735	1.99	774	2.14	812	2.25	846	2.32	882	2.40	920	2.49	959	2.58
5000	725	2.06	763	2.21	801	2.34	837	2.44	869	2.49	903	2.55	941	2.64	979	2.73
5200	754	2.30	791	2.43	828	2.55	862	2.63	891	2.66	925	2.71	962	2.79	1000	2.88
5400	783	2.53	819	2.65	855	2.75	887	2.82	913	2.82	946	2.86	983	2.95	1021	3.03
5600	810	2.74	845	2.85	881	2.95	912	3.01	935	2.98	967	3.01	1004	3.10	1041	3.19
5800	835	2.95	871	3.05	906	3.15	936	3.19	957	3.14	987	3.16	1024	3.25	1062	3.34
6000	860	3.14	896	3.25	931	3.35	960	3.37	978	3.30	1008	3.31	1045	3.40	1083	3.48

Air Volume cfm	STATIC PRESSURE EXTERNAL TO UNIT - Inches Water Gauge													
	0.9		1.0		1.1		1.2		1.3		1.4		1.5	
	RPM	BHP	RPM	BHP	RPM	BHP	RPM	BHP	RPM	BHP	RPM	BHP	RPM	BHP
2800	815	1.31	862	1.43	908	1.56	954	1.68	999	1.81	1043	1.93	1087	2.05
3000	829	1.41	875	1.53	921	1.66	966	1.78	1011	1.91	1056	2.03	1100	2.15
3200	844	1.53	889	1.65	934	1.77	979	1.89	1024	2.01	1067	2.14	1111	2.26
3400	862	1.66	906	1.78	950	1.90	994	2.02	1038	2.14	1081	2.26	1124	2.38
3600	881	1.81	925	1.93	968	2.05	1011	2.17	1054	2.29	1097	2.41	1139	2.53
3800	900	1.96	944	2.08	987	2.20	1030	2.32	1072	2.44	1114	2.56	1156	2.67
4000	920	2.10	963	2.22	1006	2.34	1048	2.46	1091	2.58	1133	2.69	1174	2.81
4200	939	2.24	982	2.36	1024	2.48	1067	2.59	1109	2.71	1151	2.83	1193	2.95
4400	959	2.39	1001	2.50	1043	2.61	1085	2.73	1127	2.85	1169	2.96	1211	3.08
4600	979	2.53	1020	2.64	1062	2.76	1104	2.87	1146	2.99	1188	3.10	1230	3.22
4800	999	2.68	1040	2.79	1082	2.90	1123	3.01	1165	3.12	1207	3.24	1248	3.35
5000	1019	2.83	1060	2.93	1101	3.04	1142	3.15	1184	3.26	1226	3.38	1267	3.49
5200	1040	2.98	1080	3.08	1121	3.19	1162	3.29	1203	3.41	1245	3.52	1286	3.63
5400	1060	3.13	1100	3.23	1140	3.33	1181	3.44	1222	3.55	1264	3.66	1305	3.77
5600	1080	3.28	1120	3.37	1160	3.48	1201	3.58	1242	3.69	1283	3.80	1324	3.91
5800	1101	3.43	1140	3.52	1180	3.62	1220	3.72	1261	3.83	1302	3.94	1343	4.05
6000	1121	3.57	1160	3.67	1200	3.77	1240	3.87	1280	3.97	1321	4.08	1362	4.19

TAA180 BLOWER PERFORMANCE

All data is measured external to the unit with dry coil and standard 2 in. air filters in place.

FOR ALL UNITS ADD:

1 - Wet indoor coil air resistance of selected unit.

2 - Any field installed accessories air resistance (electric heat, economizer, etc.) See page 14.

Then determine from table the blower motor hp and drive rpm required. See page 12 for blower drive specifications.

Air Volume cfm	STATIC PRESSURE EXTERNAL TO UNIT - Inches Water Gauge															
	0.1		0.2		0.3		0.4		0.5		0.6		0.7		0.8	
	RP M	BHP	RP M	BHP	RP M	BHP	RP M	BHP	RP M	BHP	RP M	BHP	RP M	BHP	RP M	BHP
3400	393	0.60	439	0.81	486	1.00	533	1.16	579	1.28	624	1.41	667	1.56	708	1.71
3600	398	0.66	444	0.87	491	1.06	538	1.21	583	1.33	628	1.47	671	1.62	711	1.79
3800	403	0.72	449	0.92	496	1.11	542	1.26	587	1.39	632	1.53	675	1.69	715	1.86
4000	408	0.78	454	0.98	501	1.17	547	1.32	592	1.45	636	1.60	679	1.76	718	1.94
4200	413	0.84	459	1.04	506	1.23	552	1.38	597	1.52	641	1.67	683	1.84	722	2.03
4400	419	0.90	465	1.10	512	1.29	558	1.44	602	1.58	645	1.74	687	1.92	726	2.12
4600	424	0.97	470	1.17	517	1.35	563	1.50	607	1.65	651	1.82	692	2.01	730	2.21
4800	430	1.03	476	1.23	523	1.42	569	1.57	613	1.73	656	1.90	697	2.10	735	2.31
5000	436	1.09	482	1.30	530	1.49	575	1.64	619	1.81	661	1.99	702	2.19	739	2.42
5200	442	1.15	489	1.37	536	1.56	582	1.72	625	1.89	667	2.08	707	2.29	744	2.52
5400	448	1.21	495	1.44	543	1.64	588	1.80	631	1.98	673	2.18	712	2.40	749	2.63
5600	454	1.28	502	1.52	550	1.72	595	1.89	638	2.08	679	2.28	718	2.51	754	2.75
5800	460	1.35	510	1.60	558	1.80	602	1.98	645	2.18	686	2.39	724	2.62	759	2.87
6000	467	1.43	517	1.68	566	1.89	610	2.07	652	2.28	692	2.50	729	2.74	764	2.99
6200	475	1.51	526	1.78	574	1.98	617	2.17	659	2.39	699	2.61	735	2.86	770	3.12
6400	483	1.60	534	1.87	582	2.08	625	2.28	666	2.50	705	2.73	741	2.99	775	3.25
6600	491	1.70	544	1.97	591	2.18	633	2.39	674	2.62	712	2.86	747	3.12	781	3.38
6800	501	1.81	553	2.08	600	2.29	642	2.51	682	2.74	719	2.99	753	3.26	786	3.52
7000	511	1.92	563	2.19	609	2.40	650	2.63	689	2.87	725	3.13	759	3.40	792	3.66
7200	521	2.04	573	2.30	618	2.52	659	2.76	697	3.01	732	3.27	765	3.54	798	3.80

Air Volume cfm	STATIC PRESSURE EXTERNAL TO UNIT - Inches Water Gauge													
	0.9		1.0		1.1		1.2		1.3		1.4		1.5	
	RPM	BHP	RPM	BHP	RPM	BHP	RPM	BHP	RPM	BHP	RPM	BHP	RPM	BHP
3400	746	1.87	783	2.02	819	2.16	857	2.31	897	2.48	936	2.65	976	2.83
3600	749	1.95	786	2.11	822	2.26	860	2.42	900	2.58	939	2.76	979	2.93
3800	752	2.04	789	2.21	825	2.36	863	2.52	903	2.69	943	2.86	983	3.04
4000	756	2.13	792	2.30	829	2.47	867	2.63	906	2.80	946	2.97	986	3.15
4200	759	2.22	795	2.40	832	2.57	870	2.74	910	2.91	950	3.08	990	3.26
4400	763	2.32	799	2.51	836	2.68	874	2.85	913	3.02	953	3.19	993	3.37
4600	767	2.42	803	2.61	840	2.79	878	2.96	917	3.13	957	3.31	997	3.48
4800	771	2.53	807	2.72	844	2.91	882	3.08	921	3.25	961	3.42	1001	3.59
5000	775	2.63	811	2.84	848	3.02	886	3.20	925	3.37	965	3.54	1005	3.71
5200	780	2.75	815	2.95	852	3.14	890	3.32	929	3.49	969	3.67	1009	3.84
5400	784	2.86	820	3.07	857	3.26	895	3.44	934	3.62	974	3.80	1014	3.97
5600	789	2.98	824	3.19	861	3.38	900	3.57	939	3.75	978	3.93	1018	4.11
5800	794	3.10	829	3.32	866	3.51	905	3.70	944	3.88	983	4.07	1023	4.25
6000	799	3.23	834	3.44	871	3.64	910	3.83	949	4.02	988	4.21	1028	4.40
6200	804	3.36	839	3.57	876	3.77	915	3.97	954	4.16	994	4.35	1033	4.55
6400	809	3.49	844	3.70	881	3.90	920	4.10	960	4.30	999	4.50	1039	4.70
6600	815	3.62	850	3.83	887	4.04	926	4.24	965	4.45	1005	4.65	1044	4.85
6800	820	3.76	855	3.97	892	4.18	931	4.39	971	4.59	1011	4.80	1050	5.01
7000	826	3.89	861	4.11	898	4.32	937	4.53	977	4.74	1016	4.95	1056	5.16
7200	831	4.03	866	4.25	904	4.46	943	4.67	982	4.89	1022	5.10	1062	5.32

TAA240 BLOWER PERFORMANCE

All data is measured external to the unit with dry coil and standard 2 in. air filters in place.

FOR ALL UNITS ADD:

1 - Wet indoor coil air resistance of selected unit.

2 - Any field installed accessories air resistance (electric heat, economizer, etc.) See page 14.

Then determine from table the blower motor hp and drive rpm required. See page 12 for blower drive specifications.

Air Volume cfm	STATIC PRESSURE EXTERNAL TO UNIT - Inches Water Gauge															
	0.1		0.2		0.3		0.4		0.5		0.6		0.7		0.8	
	RP M	BHP	RP M	BHP	RP M	BHP	RP M	BHP	RP M	BHP	RP M	BHP	RP M	BHP	RP M	BHP
4400	449	1.05	493	1.22	539	1.38	584	1.52	628	1.68	670	1.85	711	2.04	748	2.24
4600	456	1.11	501	1.29	546	1.45	591	1.60	635	1.76	677	1.94	717	2.14	754	2.35
4800	463	1.17	509	1.36	554	1.53	599	1.68	642	1.85	684	2.03	723	2.24	760	2.46
5000	471	1.24	517	1.44	563	1.60	607	1.76	650	1.94	691	2.14	729	2.35	766	2.58
5200	479	1.32	525	1.52	571	1.69	615	1.85	657	2.04	698	2.24	736	2.47	772	2.70
5400	487	1.40	534	1.60	580	1.77	623	1.95	665	2.14	705	2.36	743	2.59	778	2.82
5600	496	1.48	544	1.69	589	1.87	632	2.05	674	2.25	713	2.48	749	2.72	785	2.95
5800	506	1.58	554	1.79	599	1.96	641	2.16	682	2.37	720	2.60	756	2.85	791	3.08
6000	516	1.68	564	1.89	608	2.07	650	2.27	691	2.49	728	2.73	763	2.98	798	3.22
6200	527	1.78	574	1.99	618	2.18	660	2.39	699	2.62	736	2.87	771	3.12	805	3.36
6400	538	1.89	585	2.09	628	2.29	669	2.51	708	2.75	743	3.01	778	3.26	812	3.50
6600	550	2.00	596	2.21	638	2.41	679	2.64	716	2.89	751	3.15	785	3.41	819	3.65
6800	562	2.12	607	2.33	649	2.54	688	2.78	725	3.04	759	3.30	793	3.56	826	3.79
7000	574	2.24	619	2.45	659	2.68	698	2.93	733	3.19	767	3.46	800	3.71	834	3.95
7200	587	2.36	630	2.59	670	2.83	707	3.08	742	3.34	775	3.61	808	3.87	841	4.10
7400	600	2.50	642	2.73	680	2.98	717	3.23	750	3.50	783	3.77	815	4.03	849	4.25
7600	612	2.64	653	2.88	691	3.13	726	3.40	759	3.67	791	3.94	823	4.19	856	4.41
7800	625	2.79	664	3.03	701	3.29	735	3.56	767	3.84	799	4.10	831	4.35	864	4.56
8000	638	2.94	676	3.20	711	3.46	744	3.73	776	4.01	807	4.27	839	4.51	872	4.72
8200	650	3.11	687	3.36	721	3.63	753	3.91	784	4.18	815	4.44	847	4.67	880	4.88
8400	662	3.27	698	3.54	731	3.81	762	4.08	793	4.36	823	4.61	855	4.84	888	5.04
8600	674	3.45	708	3.72	740	3.99	771	4.26	801	4.54	832	4.79	863	5.00	896	5.20
8800	685	3.63	719	3.90	750	4.17	780	4.45	809	4.72	840	4.96	871	5.17	904	5.36
9000	697	3.81	729	4.09	759	4.36	788	4.63	818	4.90	848	5.13	880	5.34	913	5.52
9200	708	4.00	739	4.28	768	4.55	797	4.82	826	5.08	857	5.30	888	5.50	921	5.69
9400	718	4.20	748	4.47	777	4.74	806	5.01	835	5.26	865	5.48	897	5.67	929	5.85
9600	729	4.39	758	4.67	786	4.94	814	5.20	843	5.44	874	5.65	905	5.84	938	6.01

Air Volume cfm	STATIC PRESSURE EXTERNAL TO UNIT - Inches Water Gauge													
	0.9		1.0		1.1		1.2		1.3		1.4		1.5	
	RPM	BHP	RPM	BHP	RPM	BHP	RPM	BHP	RPM	BHP	RPM	BHP	RPM	BHP
4400	785	2.44	821	2.61	858	2.78	897	2.93	936	3.09	977	3.24	1017	3.40
4600	790	2.55	826	2.73	864	2.90	902	3.06	942	3.21	982	3.37	1022	3.53
4800	796	2.66	832	2.85	869	3.02	908	3.18	948	3.34	988	3.50	1028	3.66
5000	801	2.79	837	2.97	875	3.14	914	3.31	954	3.48	994	3.64	1034	3.81
5200	807	2.91	843	3.10	881	3.27	920	3.45	960	3.62	1000	3.79	1040	3.96
5400	813	3.04	850	3.23	888	3.41	927	3.58	967	3.76	1007	3.94	1047	4.11
5600	820	3.17	856	3.36	894	3.54	934	3.73	974	3.91	1014	4.09	1053	4.27
5800	826	3.30	863	3.49	901	3.68	941	3.87	981	4.06	1021	4.24	1060	4.43
6000	833	3.43	869	3.63	908	3.82	948	4.01	988	4.21	1028	4.40	1068	4.59
6200	840	3.57	876	3.77	915	3.96	955	4.16	995	4.36	1035	4.55	1075	4.75
6400	847	3.71	883	3.91	922	4.11	962	4.31	1002	4.51	1042	4.71	1082	4.91
6600	854	3.86	890	4.06	929	4.25	969	4.45	1009	4.66	1049	4.86	1089	5.06
6800	861	4.00	898	4.20	936	4.40	976	4.60	1016	4.80	1056	5.00	1096	5.20
7000	868	4.15	905	4.35	943	4.54	983	4.74	1023	4.94	1063	5.14	1103	5.34
7200	876	4.30	912	4.50	950	4.69	990	4.88	1030	5.08	1070	5.28	1110	5.48
7400	883	4.45	920	4.64	958	4.83	997	5.03	1037	5.22	1077	5.42	1117	5.62
7600	891	4.61	927	4.79	965	4.98	1004	5.17	1044	5.37	1084	5.56	1124	5.76
7800	899	4.76	935	4.95	973	5.13	1012	5.32	1051	5.51	1091	5.71	1131	5.90
8000	907	4.91	943	5.10	980	5.28	1019	5.47	1059	5.66	1098	5.85	1138	6.04
8200	914	5.07	950	5.25	988	5.43	1027	5.62	1066	5.80	1106	5.99	1145	6.18
8400	922	5.23	958	5.41	996	5.58	1034	5.77	1073	5.95	1113	6.14	1153	6.33
8600	930	5.38	966	5.56	1003	5.74	1042	5.92	1081	6.10	1120	6.28	1160	6.47
8800	938	5.54	974	5.71	1011	5.89	1049	6.07	1088	6.25	1128	6.43	1167	6.62
9000	947	5.70	982	5.87	1019	6.04	1057	6.22	1096	6.40	1135	6.58	1175	6.76
9200	955	5.86	990	6.03	1027	6.20	1065	6.37	1104	6.54	1143	6.72	1182	6.91
9400	963	6.02	998	6.18	1035	6.35	1073	6.52	1111	6.69	1150	6.87	1190	7.05
9600	971	6.18	1007	6.34	1043	6.50	1081	6.67	1119	6.84	1158	7.02	1197	7.20

BLOWER DRIVE SPECIFICATIONS

Static	RPM Range	Motor HP		072	090	120	150	180	240
		Nominal	Maximum						
Low	552 - 782	1.5	1.72	○	---	---	---	---	---
Standard	690 - 936	1.5	1.72	S	---	---	---	---	---
High	906 - 1121	2	2.3	○	---	---	---	---	---
Low	644 - 874	2	2.3	---	○	---	---	---	---
Standard	782 - 1012	2	2.3	---	S	---	---	---	---
High	966 - 1196	3	3.45	---	○	---	---	---	---
Low	690 - 893	2	2.3	---	---	○	---	---	---
Standard	852 - 1055	2	2.3	---	---	S	---	---	---
High	986 - 1232	3	3.45	---	---	○	---	---	---
Low	782 - 1012	3	3.45	---	---	---	○	---	---
Standard	920 - 1150	3	3.45	---	---	---	S	---	---
High	1134 - 1380	5	5.75	---	---	---	○	---	---
Low	591 - 838	3	3.45	---	---	---	---	○	---
Standard	782 - 1012	5	5.75	---	---	---	---	S	---
High	920 - 1150	5	5.75	---	---	---	---	○	---
Low	679 - 863	5	5.75	---	---	---	---	---	○
Standard	808 - 1026	7.5	8.63	---	---	---	---	---	S
High	1002 - 1282	7.5	8.63	---	---	---	---	---	○

NOTE - Using total air volume and system static pressure requirements, determine from blower performance tables rpm and motor horsepower required. Maximum usable horsepower of motors furnished by Lennox are shown. In Canada, nominal motor horsepower is also maximum usable motor horsepower. If motors of comparable horsepower are used, be sure to keep within the service factor limitations outlined on the motor nameplate.

S - Factory installed standard

○ - Factory Installed with extended lead time.

BLOWER MOTOR ELECTRICAL DATA

			Model No.	072	090	120	150	180	240
1.5 HP Blower Motor	Maximum Overcurrent Protection / Minimum Circuit Ampacity	208/230/-60hz-3ph	15 / 8	---	---	---	---	---	---
		460V-60hz-3ph	15 / 4	---	---	---	---	---	---
		575V-60hz-3ph	15 / 3	---	---	---	---	---	---
2 HP Blower Motor	Maximum Overcurrent Protection / Minimum Circuit Ampacity	208/230/-60hz-3ph	15 / 10	15 / 10	15 / 10	---	---	---	---
		460V-60hz-3ph	15 / 5	15 / 5	15 / 5	---	---	---	---
		575V-60hz-3ph	15 / 4	15 / 4	15 / 4	---	---	---	---
3 HP Blower Motor	Maximum Overcurrent Protection / Minimum Circuit Ampacity	208/230/-60hz-3ph	---	20 / 14	20 / 14	20 / 14	20 / 14	20 / 14	---
		460V-60hz-3ph	---	15 / 6	15 / 6	15 / 6	15 / 6	15 / 6	---
		575V-60hz-3ph	---	15 / 5	15 / 5	15 / 5	15 / 5	15 / 5	---
5 HP Blower Motor	Maximum Overcurrent Protection / Minimum Circuit Ampacity	208/230/-60hz-3ph	---	---	---	35 / 21	35 / 21	35 / 21	35 / 21
		460V-60hz-3ph	---	---	---	15 / 10	15 / 10	15 / 10	15 / 10
		575V-60hz-3ph	---	---	---	15 / 8	15 / 8	15 / 8	15 / 8
7.5 HP Blower Motor	Maximum Overcurrent Protection / Minimum Circuit Ampacity	208/230/-60hz-3ph	---	---	---	---	---	---	50 / 31
		460V-60hz-3ph	---	---	---	---	---	---	20 / 14
		575V-60hz-3ph	---	---	---	---	---	---	20 / 12

TAA072-090 ACCESSORY AIR RESISTANCE

ID AIR CFM	TAA072 Wet Coil Drop	TAA090 Wet Coil Drop	MERV 10	MERV15	Economizer	Electric heat	Hot Water Coil
1600	0.05	0.07	0.02	0.04	0.02	0.00	0.08
1700	0.06	0.08	0.02	0.04	0.03	0.00	0.09
1800	0.06	0.09	0.02	0.04	0.03	0.00	0.10
1900	0.07	0.09	0.03	0.04	0.04	0.02	0.12
2000	0.07	0.10	0.03	0.04	0.04	0.02	0.13
2100	0.08	0.11	0.03	0.04	0.04	0.02	0.14
2200	0.08	0.11	0.03	0.05	0.05	0.02	0.15
2300	0.09	0.12	0.03	0.05	0.05	0.03	0.16
2400	0.10	0.13	0.04	0.06	0.05	0.03	0.17
2500	0.10	0.14	0.04	0.06	0.06	0.03	0.18
2600	0.11	0.15	0.04	0.06	0.06	0.03	0.19
2700	0.12	0.16	0.05	0.06	0.07	0.04	0.20
2800	0.12	0.17	0.05	0.06	0.07	0.04	0.22
2900	0.13	0.18	0.05	0.07	0.08	0.04	0.23
3000	0.14	0.19	0.05	0.07	0.08	0.05	0.24
3100	0.14	0.20	0.06	0.07	0.09	0.05	0.25
3200	0.15	0.21	0.06	0.07	0.09	0.05	0.27
3300	0.16	0.22	0.06	0.08	0.10	0.06	0.28
3400	0.17	0.23	0.06	0.08	0.10	0.06	0.30
3500	0.18	0.24	0.07	0.08	0.11	0.06	0.31
3600	0.18	0.25	0.07	0.08	0.12	0.06	0.32

TAA120-150 ACCESSORY AIR RESISTANCE

ID AIR	TAA120 Wet Coil Drop	TAA150 Wet Coil Drop	MERV 10	MERV15	Economizer	Electric heat	Hot Water Coil
2200	0.07	0.07	0.02	0.04	0.03	0.03	0.15
2400	0.08	0.08	0.03	0.04	0.03	0.03	0.17
2600	0.09	0.09	0.03	0.05	0.03	0.04	0.20
2800	0.10	0.10	0.03	0.05	0.04	0.04	0.22
3000	0.11	0.11	0.04	0.05	0.04	0.05	0.24
3200	0.12	0.12	0.04	0.05	0.04	0.05	0.27
3400	0.14	0.14	0.04	0.06	0.05	0.06	0.30
3600	0.15	0.15	0.05	0.06	0.05	0.06	0.32
3800	0.16	0.16	0.05	0.07	0.05	0.06	0.35
4000	0.18	0.18	0.06	0.07	0.06	0.08	0.38
4200	0.19	0.19	0.06	0.07	0.06	0.08	0.41
4400	0.20	0.20	0.06	0.08	0.07	0.09	0.44
4600	0.22	0.22	0.07	0.08	0.07	0.09	0.48
4800	0.23	0.23	0.07	0.08	0.08	0.10	0.51
5000	0.25	0.25	0.07	0.08	0.08	0.10	0.54
5200	0.27	0.27	0.08	0.09	0.09	0.11	0.58
5400	0.28	0.28	0.08	0.09	0.09	0.11	0.62
5600	0.30	0.30	0.08	0.09	0.10	0.13	0.65
5800	0.32	0.32	0.09	0.10	0.10	0.13	0.69
6000	0.33	0.33	0.09	0.10	0.11	0.14	0.73

TAA180-240 ACCESSORY AIR RESISTANCE

ID AIR	TAA180 Wet Coil Drop	TAA240 Wet Coil Drop	MERV 10	MERV15	Economizer	Electric heat	Hot Water Coil
3250	0.07	0.06	0.01	0.04	0.02	0.04	0.16
3500	0.07	0.07	0.01	0.04	0.02	0.05	0.18
3750	0.08	0.08	0.01	0.04	0.03	0.06	0.20
4000	0.08	0.09	0.01	0.04	0.03	0.06	0.22
4250	0.09	0.09	0.02	0.05	0.03	0.07	0.23
4500	0.09	0.11	0.03	0.05	0.05	0.07	0.24
4750	0.10	0.12	0.04	0.05	0.06	0.08	0.26
5000	0.10	0.13	0.04	0.06	0.07	0.09	0.29
5250	0.11	0.14	0.04	0.06	0.07	0.09	0.31
5500	0.11	0.15	0.05	0.06	0.08	0.11	0.33
5750	0.12	0.16	0.05	0.06	0.08	0.11	0.36
6000	0.13	0.18	0.05	0.07	0.10	0.12	0.38
6250	0.14	0.19	0.06	0.07	0.11	0.14	0.41
6500	0.15	0.20	0.06	0.07	0.11	0.14	0.43
6750	0.16	0.21	0.06	0.08	0.12	0.15	0.46
7000	0.17	0.22	0.07	0.08	0.12	0.15	0.49
7250	0.18	0.24	0.07	0.08	0.13	0.17	0.52
7500	0.19	0.25	0.07	0.08	0.13	0.17	0.54
7750	0.19	0.26	0.08	0.09	0.14	0.18	0.57
8000	0.21	0.28	0.08	0.09	0.16	0.20	0.60
8250	0.22	0.29	0.08	0.09	0.16	0.20	0.63
8500	0.23	0.31	0.09	0.10	0.17	0.21	0.66
8750	0.24	0.32	0.09	0.10	0.17	0.21	0.70
9000	0.25	0.33	0.09	0.10	0.18	0.23	0.73
9250	0.26	0.35	0.10	0.11	0.19	0.24	0.76
9500	0.27	0.36	0.10	0.11	0.20	0.26	0.79
9750	0.28	0.38	0.10	0.11	0.22	0.27	0.83
10000	0.29	0.40	0.11	0.12	0.23	0.29	0.86

TAA072 OPTIONAL ELECTRIC HEAT DATA

Electric Heat Size	No. of Steps	Volts Input	kW Input	1 Btuh Output	2 Total Unit + Electric Heat Minimum Circuit Ampacity		Total Unit + Electric Heat Maximum Overcurrent Protection	
					1.5 hp	2 hp	1.5 hp	2 hp
10 kW	1	208	7.5	25,600	34	36	35	40
	1	220	8.4	28,700	38	40	40	40
		230	9.2	31,400				
		240	10	34,100				
1	440	8.4	28,700	19	20	20	20	
	460	9.2	31,400					
	480	10	34,100					
1	550	8.4	28,700	15	16	15	20	
	575	9.2	31,400					
	600	10	34,100					
15 kW	1	208	11.3	38,400	47	49	50	50
	1	220	12.6	43,000	53	55	60	60
		230	13.5	47,000				
		240	15	51,200				
1	440	12.6	43,000	27	27	30	30	
	460	13.5	47,000					
	480	15	51,200					
1	550	12.6	43,000	21	22	25	25	
	575	13.5	47,000					
	600	15	51,200					
25 kW	³ 2	208	18.8	64,100	73	75	80	80
	³ 2	220	21	71,700	83	85	90	90
		230	23	78,300				
		240	25	85,300				
1	440	21	71,700	42	42	45	45	
	460	23	78,300					
	480	25	85,300					
1	550	21	71,700	34	34	35	35	
	575	23	78,300					
	600	25	85,300					

¹ Electric heater capacity only - does not include additional blower motor heat capacity.

² Refer to National or Canadian Electrical Code manual to determine wire, fuse and disconnect size requirements. Use wires suitable for at least 167°F.

³ May be used with two stage control (field provided).

TAA090 OPTIONAL ELECTRIC HEAT DATA

Electric Heat Size	No. of Steps	Volts Input	kW Input	1 Btuh Output	2 Total Unit + Electric Heat Minimum Circuit Ampacity		Total Unit + Electric Heat Maximum Overcurrent Protection	
					2 hp	3 hp	2 hp	3 hp
10 kW	1	208	7.5	25,600	36	40	40	40
	1	220	8.4	28,700	40	44	40	45
		230	9.2	31,400				
		240	10	34,100				
1	440	8.4	28,700	20	21	20	25	
	460	9.2	31,400					
	480	10	34,100					
1	550	8.4	28,700	16	17	20	20	
	575	9.2	31,400					
	600	10	34,100					
15 kW	1	208	11.3	38400	49	53	50	60
	1	220	12.6	43,000	55	59	60	60
		230	13.5	47,000				
		240	15	51,200				
1	440	12.6	43,000	27	29	30	30	
	460	13.5	47,000					
	480	15	51,200					
1	550	12.6	43,000	22	23	25	25	
	575	13.5	47,000					
	600	15	51,200					
25 kW	³ 2	208	18.8	64,100	75	79	80	80
	³ 2	220	21	71,700	85	89	90	90
		230	23	78,300				
		240	25	85,300				
1	440	21	71,700	42	44	45	45	
	460	23	78,300					
	480	25	85,300					
1	550	21	71,700	34	35	35	35	
	575	23	78,300					
	600	25	85,300					
33.3 kW	³ 2	208	25	85,300	97	100	100	100
	³ 2	220	28	95,500	110	114	110	125
		230	30.6	104,400				
		240	33.3	113,700				
1	440	28	95,500	55	57	60	60	
	460	30.6	104,400					
	480	33.3	113,700					
1	550	28	95,500	44	45	45	45	
	575	30.6	104,400					
	600	33.3	113,700					

¹ Electric heater capacity only - does not include additional blower motor heat capacity.

² Refer to National or Canadian Electrical Code manual to determine wire, fuse and disconnect size requirements. Use wires suitable for at least 167°F.

³ May be used with two stage control (field provided).

TAA120 OPTIONAL ELECTRIC HEAT DATA

Electric Heat Size	No. of Steps	Volts Input	kW Input	1 Btuh Output	2 Total Unit + Electric Heat Minimum Circuit Ampacity		Total Unit + Electric Heat Maximum Overcurrent Protection	
					2 hp	3 hp	2 hp	3 hp
10 kW	1	208	7.5	25,600	36	40	40	40
	1	220	8.4	28,700	40	44	40	45
		230	9.2	31,400				
		240	10	34,100				
1	440	8.4	28,700	20	21	20	25	
	460	9.2	31,400					
	480	10	34,100					
1	550	8.4	28,700	16	17	20	20	
	575	9.2	31,400					
	600	10	34,100					
15 kW	1	208	11.3	38400	49	53	50	60
	1	220	12.6	43,000	55	59	60	60
		230	13.5	47,000				
		240	15	51,200				
1	440	12.6	43,000	27	29	30	30	
	460	13.5	47,000					
	480	15	51,200					
1	550	12.6	43,000	22	23	25	25	
	575	13.5	47,000					
	600	15	51,200					
25 kW	³ 2	208	18.8	64,100	75	79	80	80
	³ 2	220	21	71,700	85	89	90	90
		230	23	78,300				
		240	25	85,300				
1	440	21	71,700	42	44	45	45	
	460	23	78,300					
	480	25	85,300					
1	550	21	71,700	34	35	35	35	
	575	23	78,300					
	600	25	85,300					
33.3 kW	³ 2	208	25	85,300	97	100	100	100
	³ 2	220	28	95,500	110	114	110	125
		230	30.6	104,400				
		240	33.3	113,700				
1	440	28	95,500	55	57	60	60	
	460	30.6	104,400					
	480	33.3	113,700					
1	550	28	95,500	44	45	45	45	
	575	30.6	104,400					
	600	33.3	113,700					

¹ Electric heater capacity only - does not include additional blower motor heat capacity.

² Refer to National or Canadian Electrical Code manual to determine wire, fuse and disconnect size requirements. Use wires suitable for at least 167°F.

³ May be used with two stage control (field provided).

TAA150 OPTIONAL ELECTRIC HEAT DATA

Electric Heat Size	No. of Steps	Volts Input	kW Input	1 Btuh Output	2 Total Unit + Electric Heat Minimum Circuit Ampacity		Total Unit + Electric Heat Maximum Overcurrent Protection	
					3 hp	5 hp	3 hp	5 hp
10 kW	1	208	7.5	25,600	40	47	40	50
	1	220	8.4	28,700	44	51	45	60
		230	9.2	31,400				
		240	10	34,100				
1	440	8.4	28,700	21	25	25	25	
	460	9.2	31,400					
	480	10	34,100					
1	550	8.4	28,700	17	20	20	20	
	575	9.2	31,400					
	600	10	34,100					
15 kW	1	208	11.3	38400	53	60	60	60
	1	220	12.6	43,000	59	66	60	70
		230	13.5	47,000				
		240	15	51,200				
1	440	12.6	43,000	29	32	30	35	
	460	13.5	47,000					
	480	15	51,200					
1	550	12.6	43,000	23	26	25	30	
	575	13.5	47,000					
	600	15	51,200					
25 kW	³ 2	208	18.8	64,100	79	86	80	90
	³ 2	220	21	71,700	89	96	90	100
		230	23	78,300				
		240	25	85,300				
1	440	21	71,700	44	48	45	50	
	460	23	78,300					
	480	25	85,300					
1	550	21	71,700	35	38	35	40	
	575	23	78,300					
	600	25	85,300					
33.3 kW	³ 2	208	25	85,300	100	108	100	110
	³ 2	220	28	95,500	114	121	125	125
		230	30.6	104,400				
		240	33.3	113,700				
1	440	28	95,500	57	60	60	60	
	460	30.6	104,400					
	480	33.3	113,700					
1	550	28	95,500	45	48	45	50	
	575	30.6	104,400					
	600	33.3	113,700					

¹ Electric heater capacity only - does not include additional blower motor heat capacity.

² Refer to National or Canadian Electrical Code manual to determine wire, fuse and disconnect size requirements. Use wires suitable for at least 167°F.

³ May be used with two stage control (field provided).

TAA180 OPTIONAL ELECTRIC HEAT DATA

Electric Heat Size	No. of Steps	Volts Input	kW Input	1 Btuh Output	² Total Unit + Electric Heat Minimum Circuit Ampacity		Total Unit + Electric Heat Maximum Overcurrent Protection	
					3 hp	5 hp	3 hp	5 hp
20 kW	1	208	14.8	50,600	65	73	70	80
	1	220	16.5	56,500	73	81	80	90
		230	18.1	61,800				
		240	19.7	67,300				
1	440	16.8	57,500	37	40	40	40	
	460	18.4	62,900					
	480	20	68,300					
1	550	16.8	57,300	29	32	30	35	
	575	18.4	62,600					
	600	20	68,300					
30 kW	2	208	22.5	76,900	92	99	100	100
	2	220	25.2	86,100	104	112	110	125
		230	27.5	94,100				
		240	30	102,500				
1	440	25.2	86,100	52	55	60	60	
	460	27.5	94,100					
	480	30	102,500					
1	550	25.2	86,200	41	44	45	45	
	575	27.5	94,200					
	600	30	102,500					
40 kW	2	208	29.3	100,000	115	123	125	125
	2	220	32.8	112,000	131	139	150	150
		230	35.8	122,300				
		240	39	133,200				
1	440	32.8	112,000	65	69	70	70	
	460	35.9	122,400					
	480	39	133,200					
1	550	33.6	114,800	53	56	60	60	
	575	36.7	125,500					
	600	40	136,600					
50 kW	2	208	36.1	123,200	114	121	125	125
	2	220	40.3	137,700	129	137	150	150
		230	44.1	150,600				
		240	48	163,900				
2	440	42	143,400	74	81	80	90	
	460	45.9	156,700					
	480	50	170,800					
2	550	42	143,500	62	69	70	70	
	575	45.9	156,800					
	600	50	170,800					

¹ Electric heater capacity only - does not include additional blower motor heat capacity.

² Refer to National or Canadian Electrical Code manual to determine wire, fuse and disconnect size requirements. Use wires suitable for at least 167°F.

³ May be used with two stage control (field provided).

TAA240 OPTIONAL ELECTRIC HEAT DATA

Electric Heat Size	No. of Steps	Volts Input	kW Input	1 Btuh Output	2 Total Unit + Electric Heat Minimum Circuit Ampacity		Total Unit + Electric Heat Maximum Overcurrent Protection	
					5 hp	7.5 hp	5 hp	7.5 hp
20 kW	1	208	14.8	50,600	73	82	80	90
	1	220	16.5	56,500	81	90	90	90
		230	18.1	61,800				
		240	19.7	67,300				
1	440	16.8	57,500	40	44	40	45	
	460	18.4	62,900					
	480	20	68,300					
1	550	16.7	57,300	32	36	35	40	
	575	18.4	62,600					
	600	20	68,300					
30 kW	2	208	22.5	76,900	99	109	100	110
	2	220	25.2	86,100	112	121	125	125
		230	27.6	94,100				
		240	30	102,500				
1	440	25.2	86,100	55	59	60	60	
	460	27.6	94,100					
	480	30	102,500					
1	550	25.2	86,100	44	48	45	50	
	575	27.6	94,200					
	600	30	102,500					
40 kW	2	208	29.3	100,000	123	132	125	150
	2	220	32.8	112,000	139	148	150	150
		230	35.8	122,300				
		240	39	133,200				
1	440	32.8	112,000	69	73	70	80	
	460	35.9	122,400					
	480	39	133,200					
1	550	33.6	114,800	56	60	60	60	
	575	36.7	125,500					
	600	40	136,600					
50 kW	2	208	36.1	123,200	121	131	125	150
	2	220	40.3	137,700	137	146	150	150
		230	44.1	150,600				
		240	48	163,900				
2	440	42	143,400	81	91	90	100	
	460	45.9	156,700					
	480	50	170,800					
2	550	42	143,500	69	79	70	80	
	575	45.9	156,800					
	600	50	170,800					

¹ Electric heater capacity only - does not include additional blower motor heat capacity.

² Refer to National or Canadian Electrical Code manual to determine wire, fuse and disconnect size requirements. Use wires suitable for at least 167°F.

³ May be used with two stage control (field provided).

I - UNIT COMPONENTS

A - Blower Contactor K3

B - Economizer Relay K43

Relay K43 is a single-pole double throw relay used to control the economizer. When there is a call for cooling, K43-1 contacts close energizing the economizer and blower contactor K3. See wiring diagram.

C - Blower Motor B3

See Page 12 for blower drive specifications and blower motor electrical data.

D - Blower Motor Overload Relay S42

Relay S42 is used for "M" voltage and units with high effi-

ciency motors only. S42 is connected in line with the blower motor to monitor the current flow to the motor. When the relay senses an overload condition, a set of N.C. contacts open to de-energize all 24 volt circuits.

E - Terminal Block TB1

All field wiring connections are made at terminal block TB1.

F - Condensate Pan and Over Flow Relay K220 & Switch S149

A reversible drain pan is provided. Never connect condensate drain to a closed system. Condensate drain line must have a trap in the line at the unit exit. K220 and S149 are field installed and used to prevent condensate overflow. In the event of a blocked drain plug and condensate begins rise, N.O. S149 will close energizing relay K220. N.C. K220 opens de-energizing the the TAA unit.

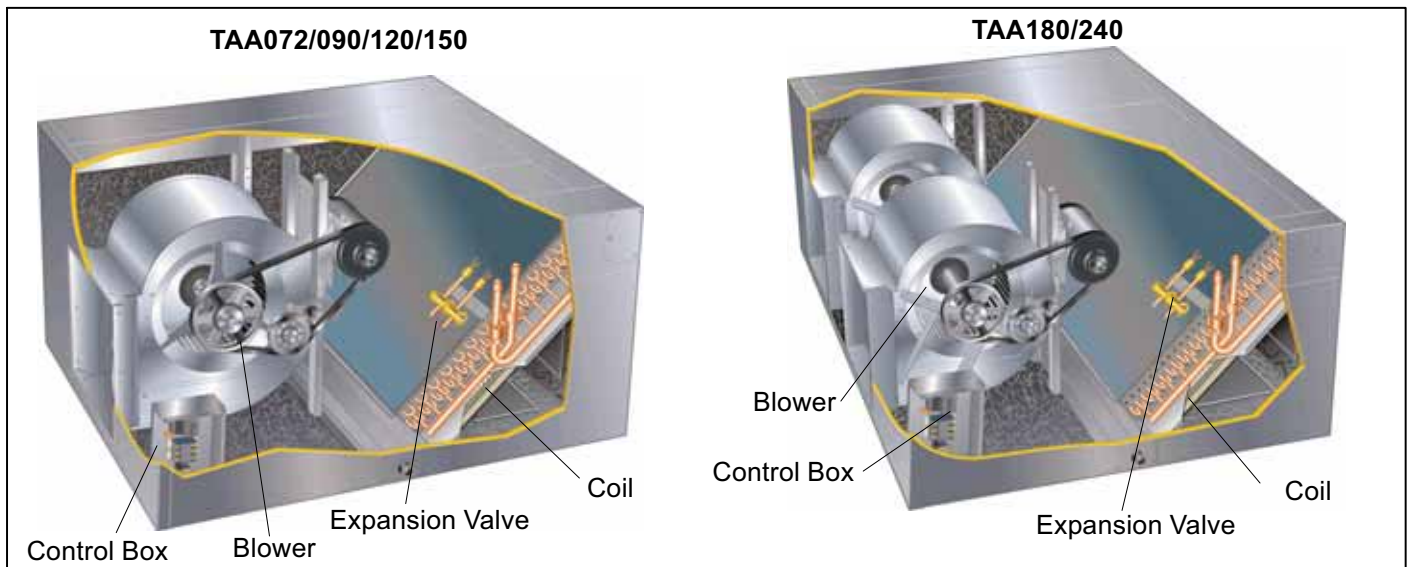

FIGURE 1

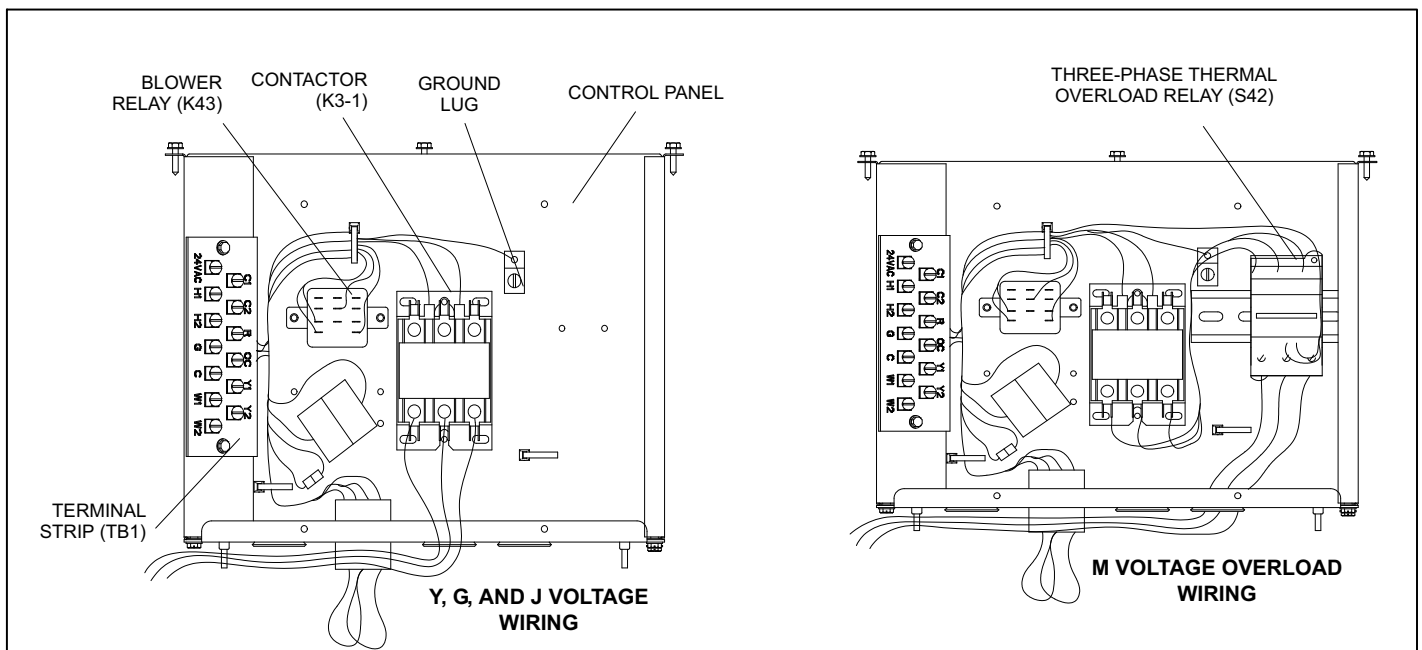

FIGURE 2

II - REFRIGERATION SYSTEM

Units are equipped with single refrigerant circuit (072) or dual refrigerant circuit (090-240). The 090-240 units have a dual distribution system for two stage capacity control during cooling cycles. Each circuit has its own service valve connection and expansion valve.

III - BLOWER SPEED & BELT TENSION

Air Volume Adjustment

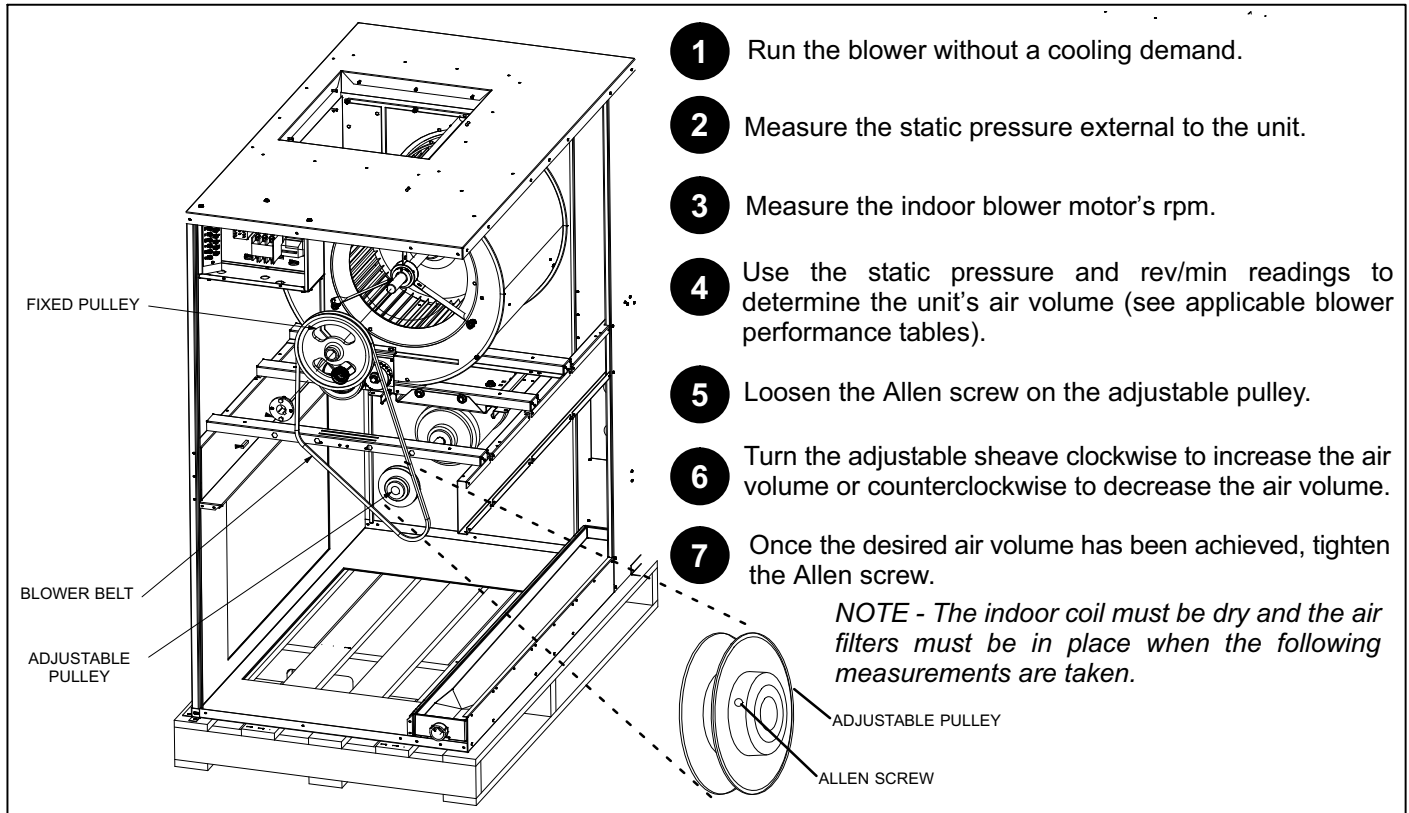

FIGURE 3

Adjusting Belt Tension

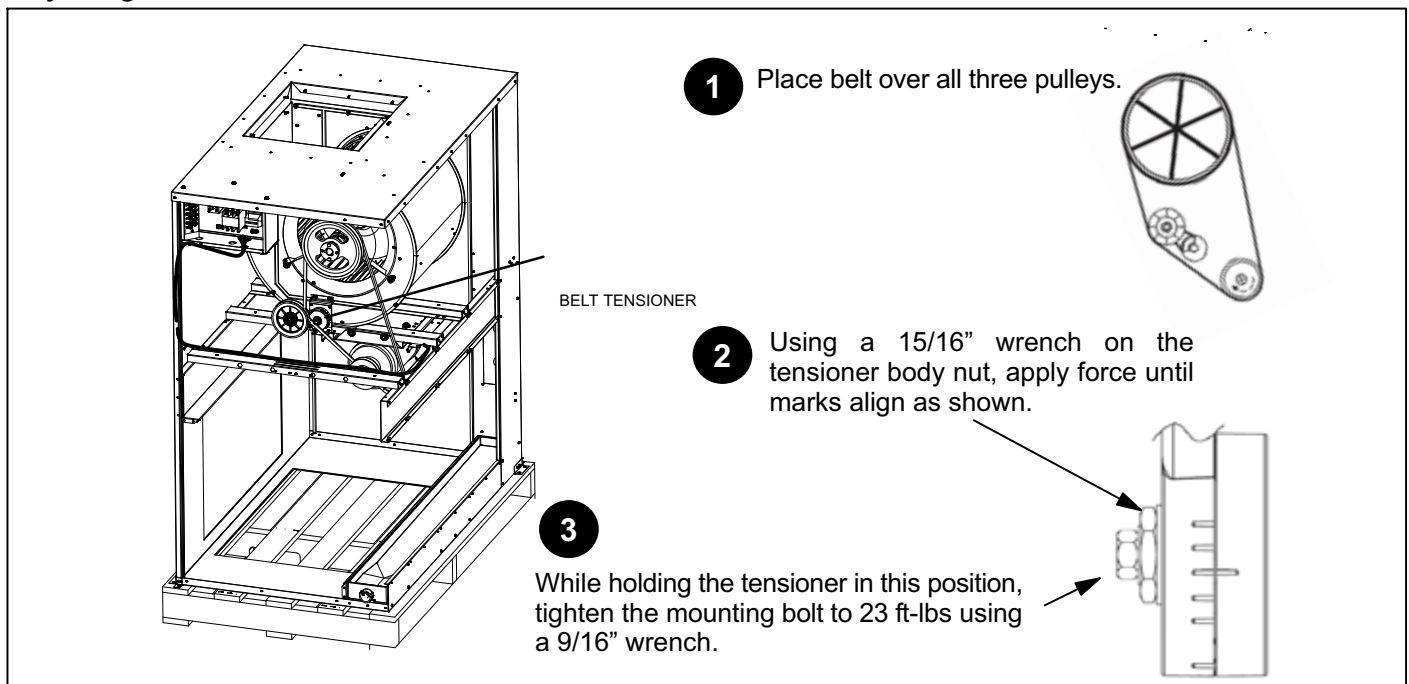

FIGURE 4

IV - Electric Heat Components

See electric heat tables (table of contents) for electric heat matchups. EHA units consists of electric heating elements exposed to the air stream. Multiple-stage elements are sequenced on and off by time delays in response to thermostat demand.

1 - Heating Elements HE1, HE2, HE3 & HE4

Heating elements are composed of helix wound bare nichrome exposed directly to the air stream. Heating elements are energized directly by contactors. Once energized, heat transfer is instantaneous. Over temperature protection is provided by primary and secondary high temperature limits. Overcurrent protection is provided by fuses. Each stage of electric heat consists of three elements connected in a three-phase arrangement. Elements in 208/230V units are connected in a "Delta" arrangement. Elements in 460 and 575V units are connected in "Wye" arrangement. Each stage is energized independently by a three-pole double-break contactor and is protected by safety limits.

2 - Contactors K15 & K16

Contactors K15 and K16 are three-pole double break relays with a 24 volt coil that energize their respective heating elements on thermostat demand. K15 energizes first stage heat elements and K16 energizes second stage elements.

3 - Electric Heat Sequencer Relays K32

Relay K32 is a N.O. sequencer relay with a resistive element for a coil and a bi-metal disk which actuates the contacts. The relays are located on the electric heat vestibule panel and are energized by a 24V heating demand (W1, W2). When energized, the internal resistance heats the bi-metal disk causing the contacts to close. When the relay is de-energized, the disk cools and the contacts open. The relay energizes different stages of heat.

4 - Relays K9 and K19

Relays K9 and K19 are used to electrically isolate the TAA 24 volts components from the T3EHA 24 volt components. The coil on the relays are connected to first stage and second stage heat. On a first stage heat demand K9 is energized. K9-1 closes energizing first stage heat contactor K15. On a second stage heat call K19 is energized. When K19-1 closes contactor K16 is energized which energizes relay K32.

5 - Fuse F3

Heating elements in all T3EHA units are protected by fuse F3. The fuse is connected in series with each leg of electric heat.

6 - Fuse F4

F4 serves the same purpose as F3 but is in line with line voltage and protects the indoor blower B3.

7 - Transformer T2

T2 is line voltage to 24VAC which provides 24VAC to power to all T3EHA contactor coils, relays and timers.

8 - High Temperature Limit S15 (Primary)

S15 is the primary high temperature limit. It is located in the electric heat unit immediately downstream from the heating elements. S15 is a single-pole single-throw normally closed thermostat wired in series with the first stage contactor coil.

When S15 opens, indicating a problem in the system, contactor K15 is de-energized. When K15 is de-energized, first stage and all subsequent stages of heat are de-energized. Since the indoor blower is controlled by demand (K9 remains energized), the indoor blower continues operating.

9 - High Temperature Limit S20 (Secondary)

Each heating element assembly is electrically connected to two high temperature limits S20 (refer to wiring diagrams in back of this manual). Each limit is connected in series with one leg of the three-phase element assembly. The third leg of each assembly is not equipped with a limit. Three-phase operating characteristics allow one of the other two limits to protect the third leg.

V - Wiring Diagrams

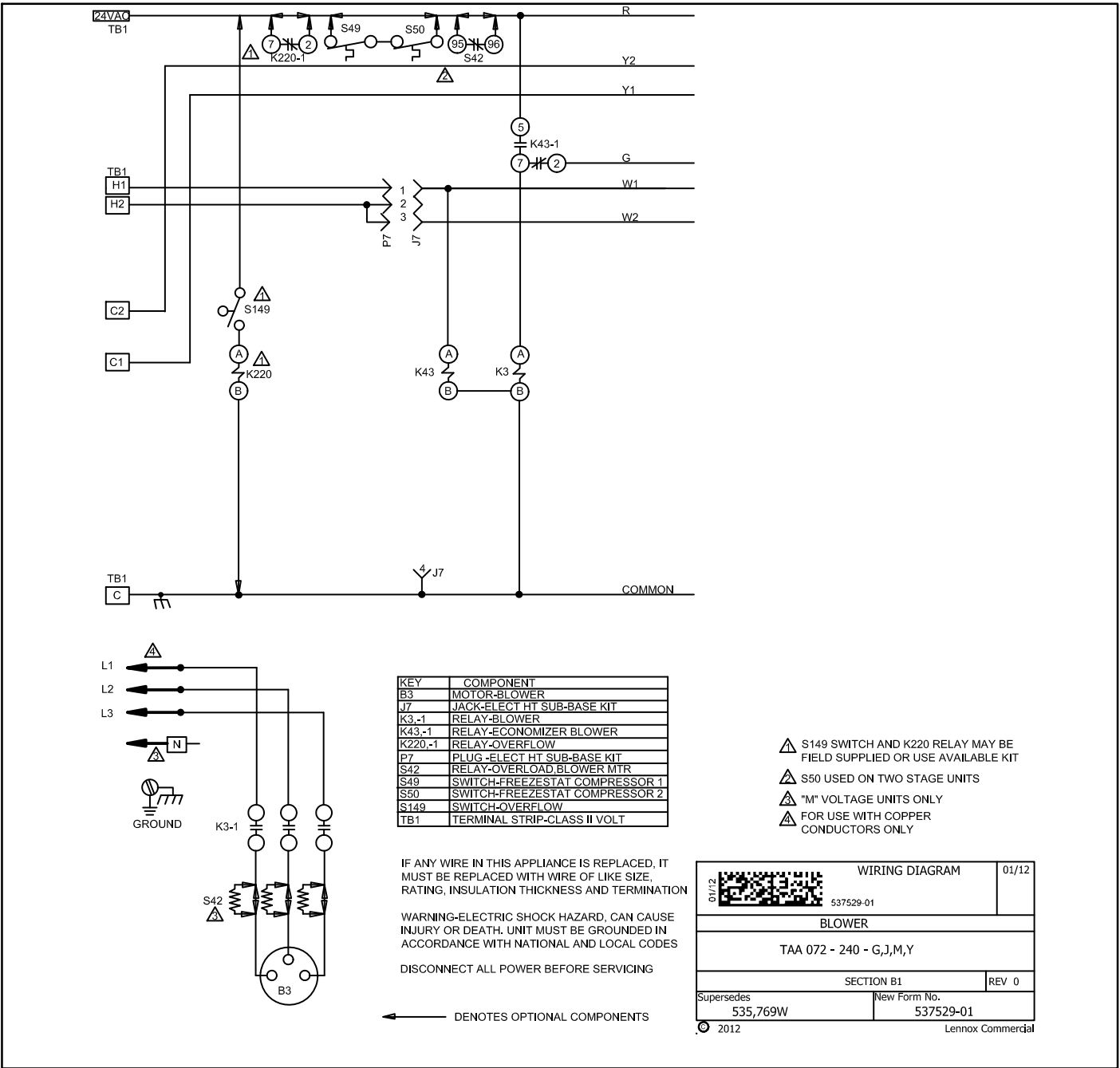

TAA072/240 - SEQUENCE OF OPERATION

1. W1 heat demand energizes the economizer relay K43.
2. When K43-1 closes blower relay K3 is energized.
3. K3-1 closes energizing indoor blower B3.

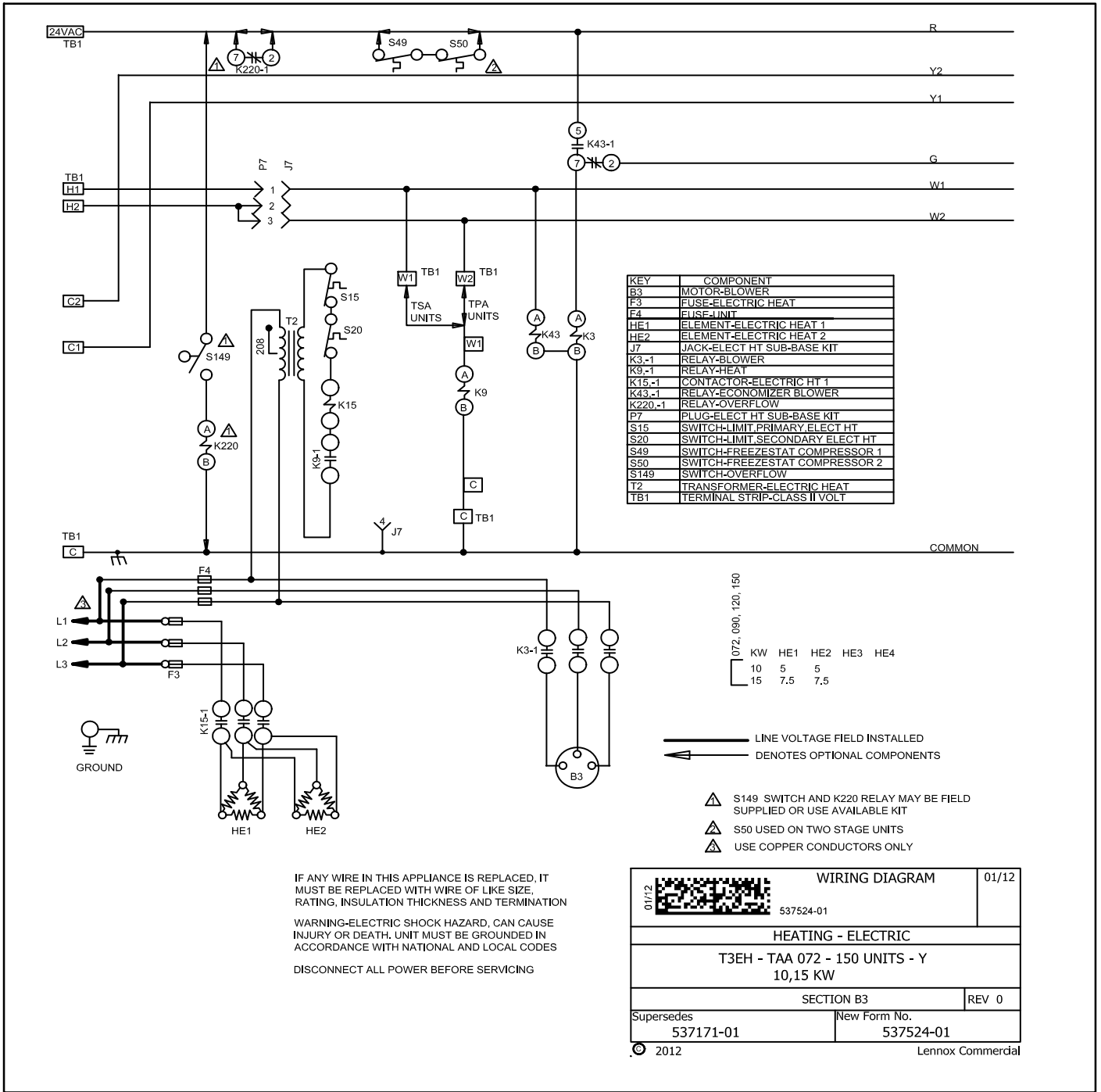

T3EH 072/150, 10-15 kW Y Voltage - Sequence of Operation

Heat Call TSA / TPA

1. W1 (W2 in TPA) heat demand energizes the economizer relay K43 and heat relay K9. K43-1 closes energizing blower relay K3.
2. K3-1 closes energizing indoor blower B3. K9-1 closes energizing contactor K15.
3. K15-1 closes and assuming primary limit S15 and secondary limit S20 are closed, heating elements HE1 and HE2 are energized.

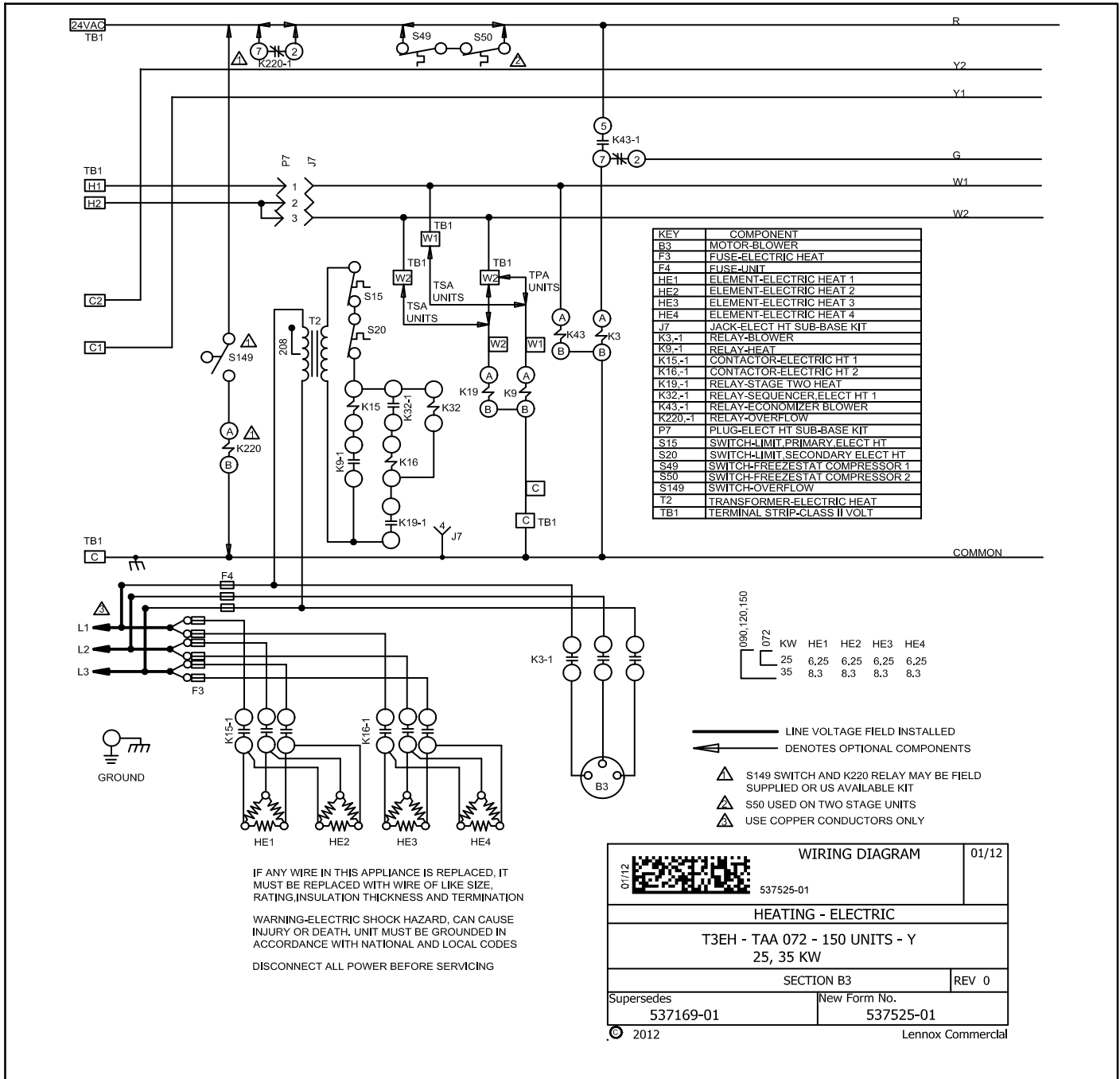

T3EH 072/150, 25-35 kW Y Voltage - Sequence of Operation

First Stage Heat Call

1. TSA - W1 heat demand energizes the economizer relay K43 and heat relay K9. K43-1 closes energizing blower relay K3
TPA - Unit will operate in "heat mode" from the indoor thermostat.
2. K3-1 closes energizing indoor blower B3. K9-1 closes energizing contactor K15. Second stage heat relay K19 is energized. (Unit is ready for second stage heat but ONLY if there is a W2 call)

3. K15-1 closes and assuming primary limit S15 and secondary limit S20 are closed, heating elements HE1 and HE2 are energized.

Second Stage Heat Call TSA / TPA

4. TSA - W2 calls for second stage heat. K19-1 closes energizing one side of contactor K16 which energizes one side of relay K32. K32-1 closes energizing K16. K16-1 closes energizing HE3 and HE4.
TPA - W2 heat demand energizes K9 and K19. K9-1 and K19-1 closes energizing K15, K16 and K32. K15-1 and K16-1 closes energizing HE3 and HE4.

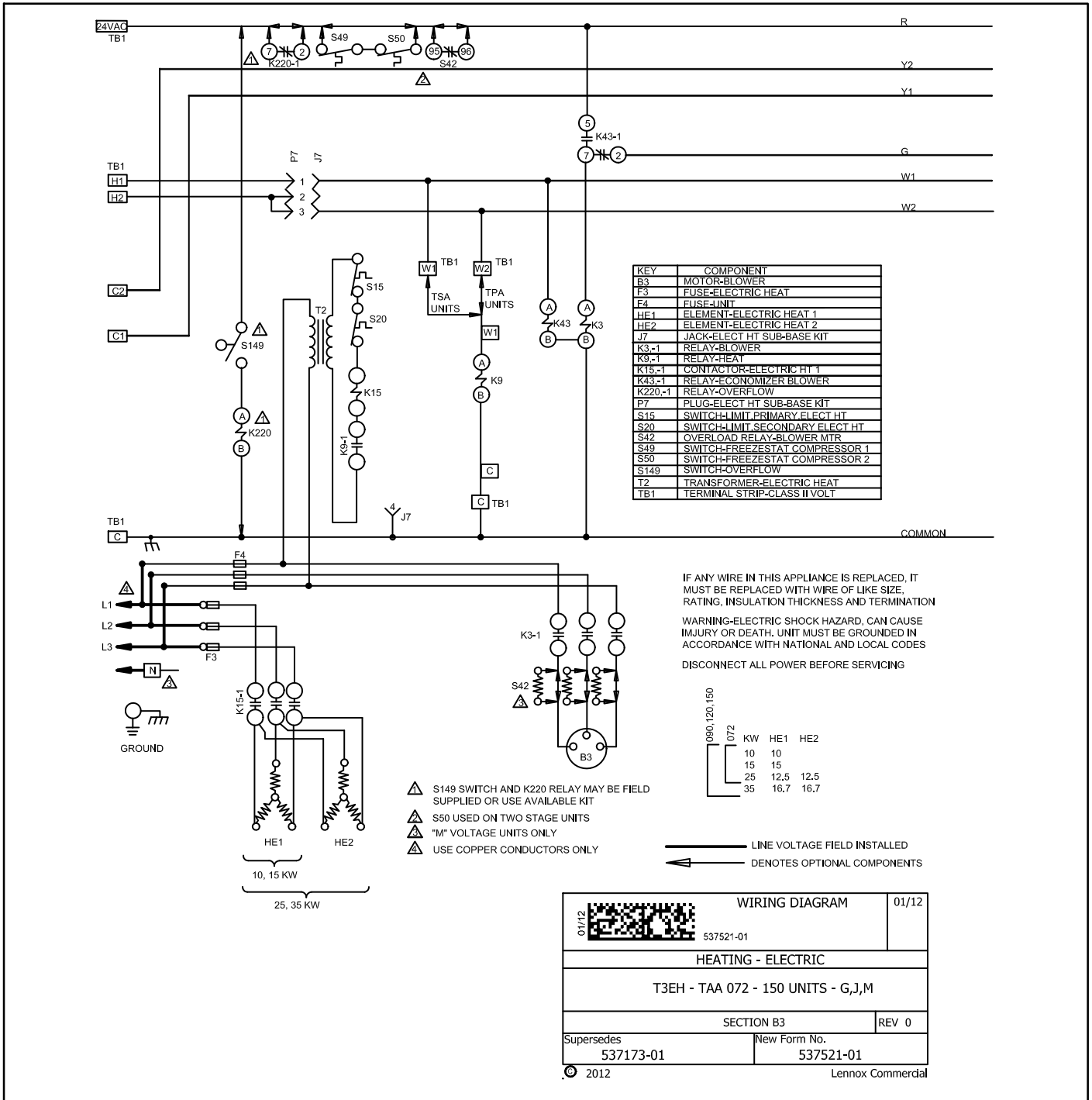

T3EH 072/150, 10-35 kW G, J, M Voltage - Sequence of Operation

Heat Call TSA / TPA

1. W1 (W2 in TPA) heat demand energizes the economizer relay K43 and heat relay K9. K43-1 closes energizing blower relay K3.
2. K3-1 closes energizing indoor blower B3. K9-1 closes energizing contactor K15.
3. K15-1 closes and assuming primary limit S15 and secondary limit S20 are closed, heating elements HE1 and HE2 are energized.